

# G0CWA (Nick's) RF SIGNAL GENERATOR

FEB 2014



Hi welcome to my design for a simple (and cheap) RF signal generator with both AM and FM modulation. The version I built was to fill in the gaps not covered by my old commercial unit and also provide an item of test equipment in its own right. As built the frequency range mine covered was 16KHz to 54 MHz although with suitable coils it should work from as low as 5KHz to over 100MHz.

This frequency range was covered in 11 ranges the twelfth being left unused and can be used as a standby setting to in some measure maintain the temperature within the case and hence minimise thermal drift, or even a din socket (I would suggest on the back) for plug in extra coils/ranges.

I soon discovered that my first ever lesson in Amateur Radio, all those years ago, held true.

***THE AMOUNT OF SPACE REQUIRED IS PROPORTIONAL TO THE AMOUNT  
AVAILABLE SQUARED !***

This law meant the case I had bought was too small and had to be enlarged as I am lazy and did not want to do any more major metal bashing, I achieved this as shown below by using longer metal bolts and a homemade case "extender".

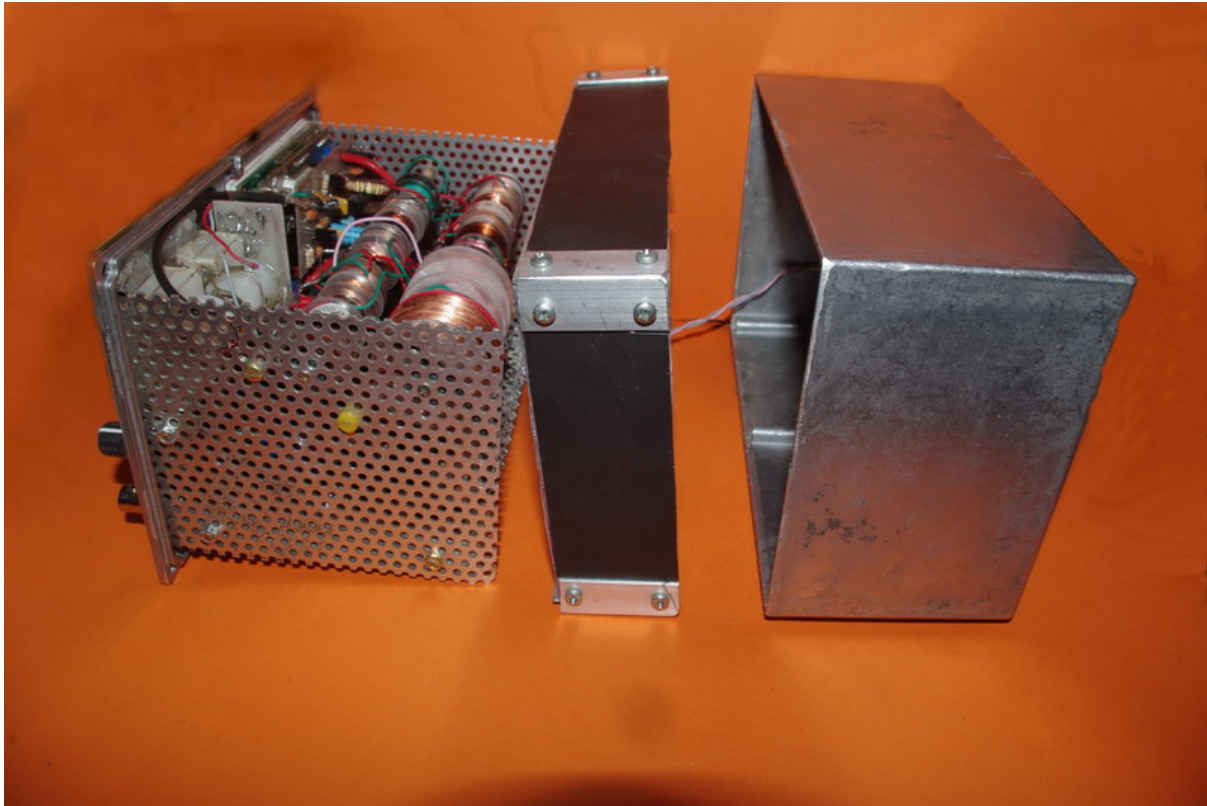

Case extender

As with all my project designs this is of a modular construction and you can build as many of the extras as you wish, I may well do some external plug on units later.

Please note calibrated dials can be used instead of the meters with, I would recommend, an external frequency meter and scope used for setting up and also using a larger case than I did.

All the coils are home wound on my coil winder

<http://makearadio.com/visitors/nicks-litz.php>

using a method I further developed

<http://makearadio.com/visitors/nick-formers.php>

Enough of an introduction now for the technical bits!

## **1. The main Board**

The main board is the only one you have to build for the minimalist version as the regulator etc. is on this board.

The circuit is based on a modulated wideband colpitts oscillator. Unfortunately with such a simple approach the signal amplitude will vary with frequency particularly as to keep it simple and the price down I have not included any form of AGC. I did look at other types of oscillator but the other configurations all had their individual problems, e.g. stability etc. The colpitts was by far the most versatile and gave the most reproducible results. I used two identical coils for the oscillator and please note the relative phasing is important to obtain feedback and hence oscillation also on some of the ranges I had to vary the coil separation to minimise any tendency for unwanted noise from being generated. The closer the coupling the higher the output but also the greater the tendency for ringing and unwanted noise (distortion of the sin wave output). The coil values I quote are for my build and a little experimentation is needed on your part to optimise your build. Unless you have a coil winder I would suggest you use commercial chokes for the high value (low frequency) coils as winding thousands of turns can be tedious and you can lose count easily.

The coil pairs should ideally be spaced at least a coil diameter apart to keep the coil interactions between ranges to a minimum with the coils axis vertical not horizontal as in my build also, hence the bigger case. The use of a class "A" power amplifier (2N3866 or similar) means the oscillator should be able to drive a 7dBm mixer directly (SBL-1 etc) on most ranges, a very useful feature.

The modulation is achieved by the use of a phase shift oscillator controlling the supply voltage to the oscillator, crude but effective, this produces amplitude and slight frequency modulation, very useful. The two presets are to set the modulation level. This is particularly important for the frequency meter module as they need to see a distinct minimum voltage change depending on

the module. Mine for example needed to see a minimum of 180mV PTP at the higher frequencies.

Hope this is enough information for you to build it, The board size is 2.2 by 3.8 inch.



Photo of main board

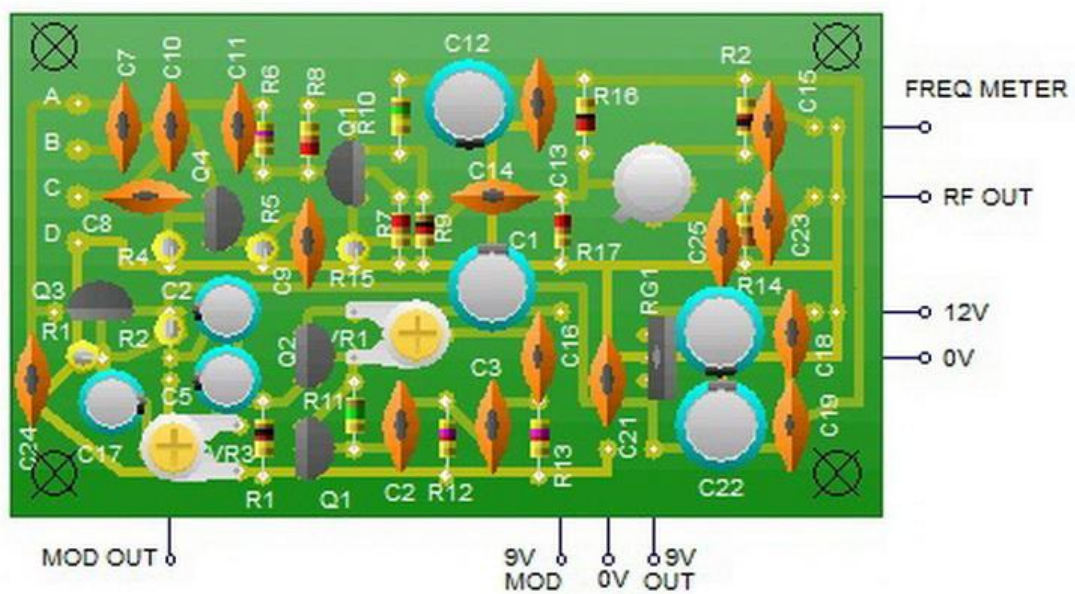

Real word image

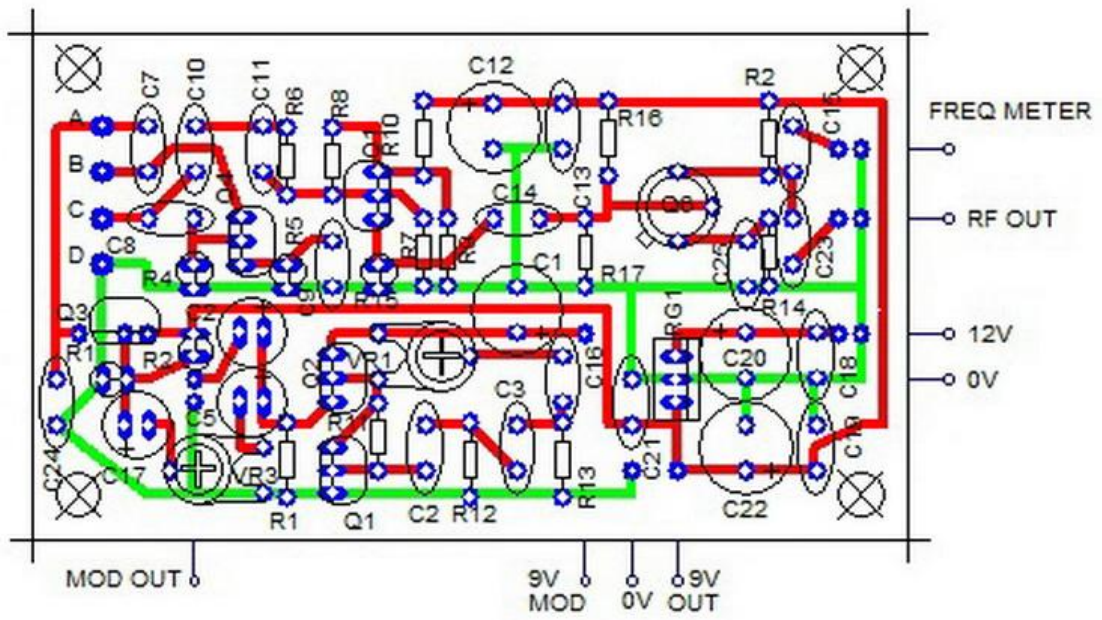

Component placement

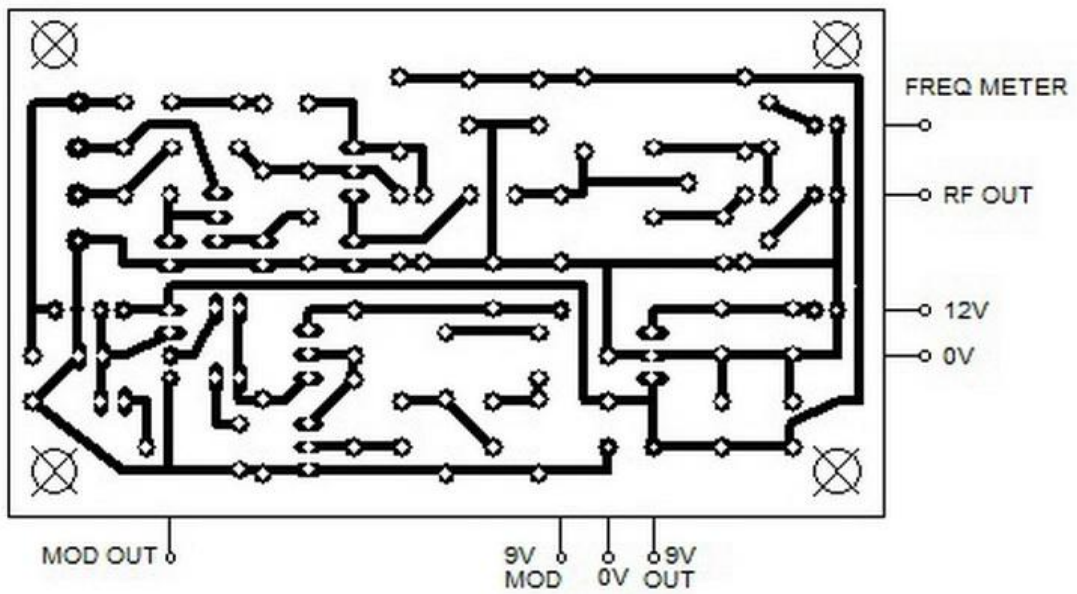

Track layout



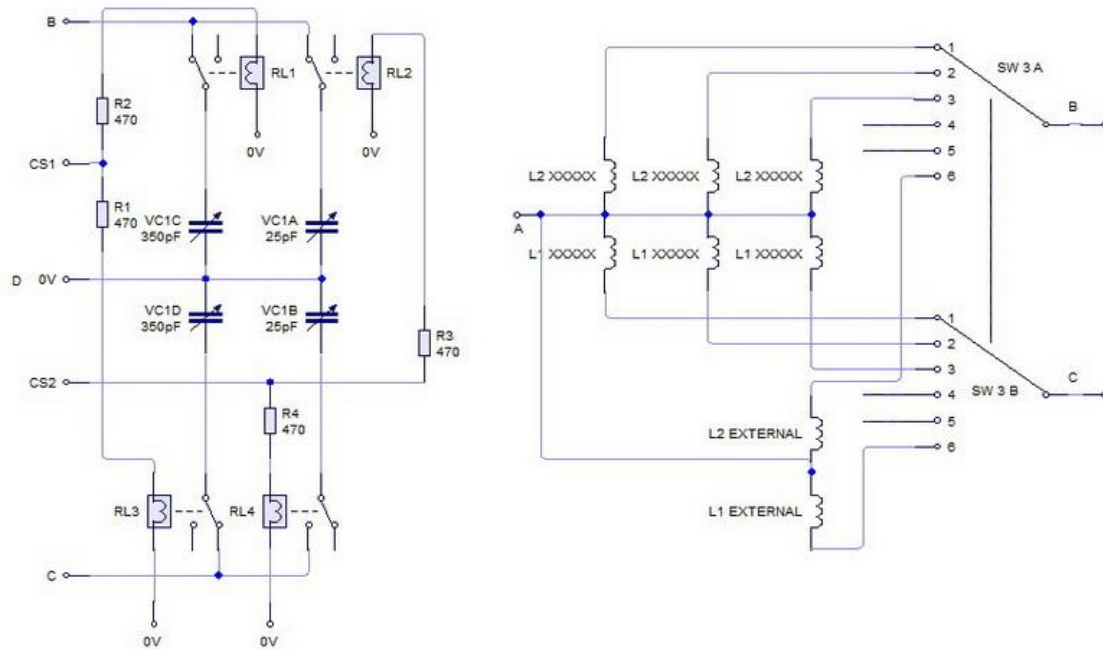

Suggested capacitor and coil switching arrangement, I used reed relays mounted on the capacitor as these tend to have the best RF behaviour at a reasonable price, **DO NOT use double pole or change over relays** as the inter-contact capacitance will severely reduce performance.

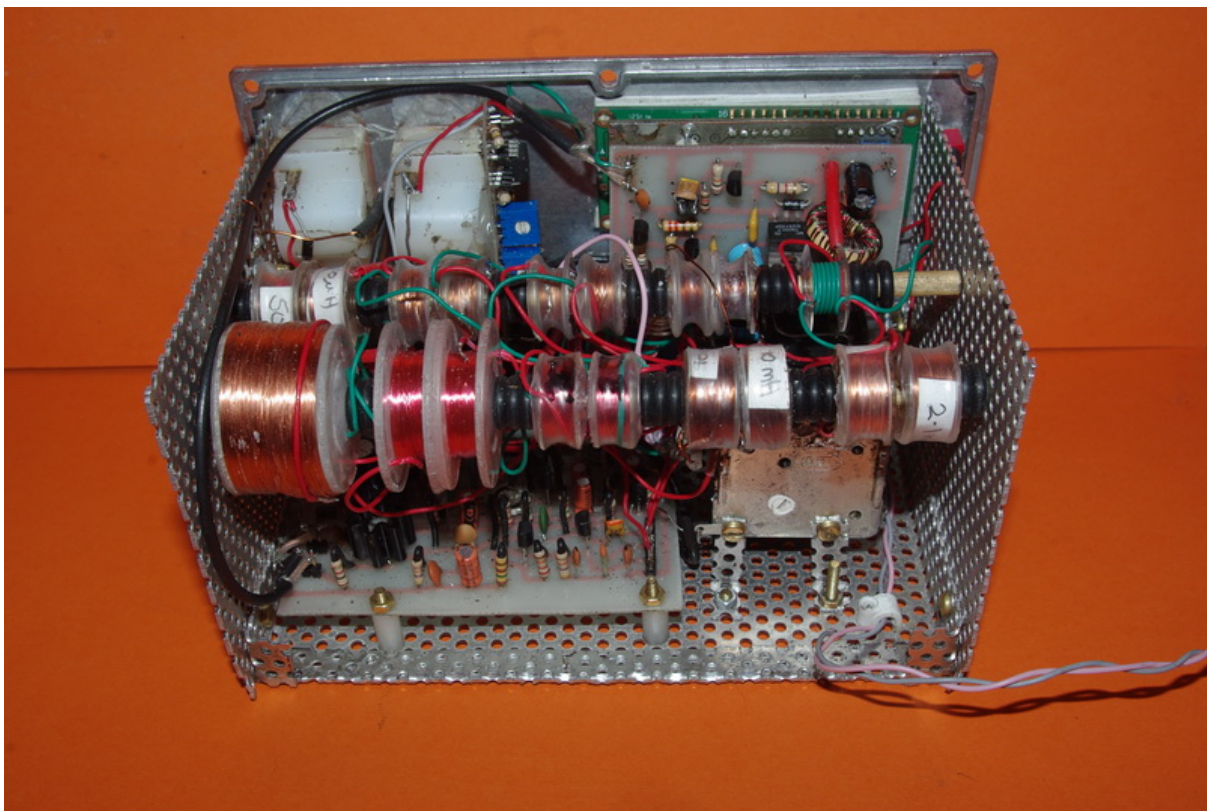

Over view 1

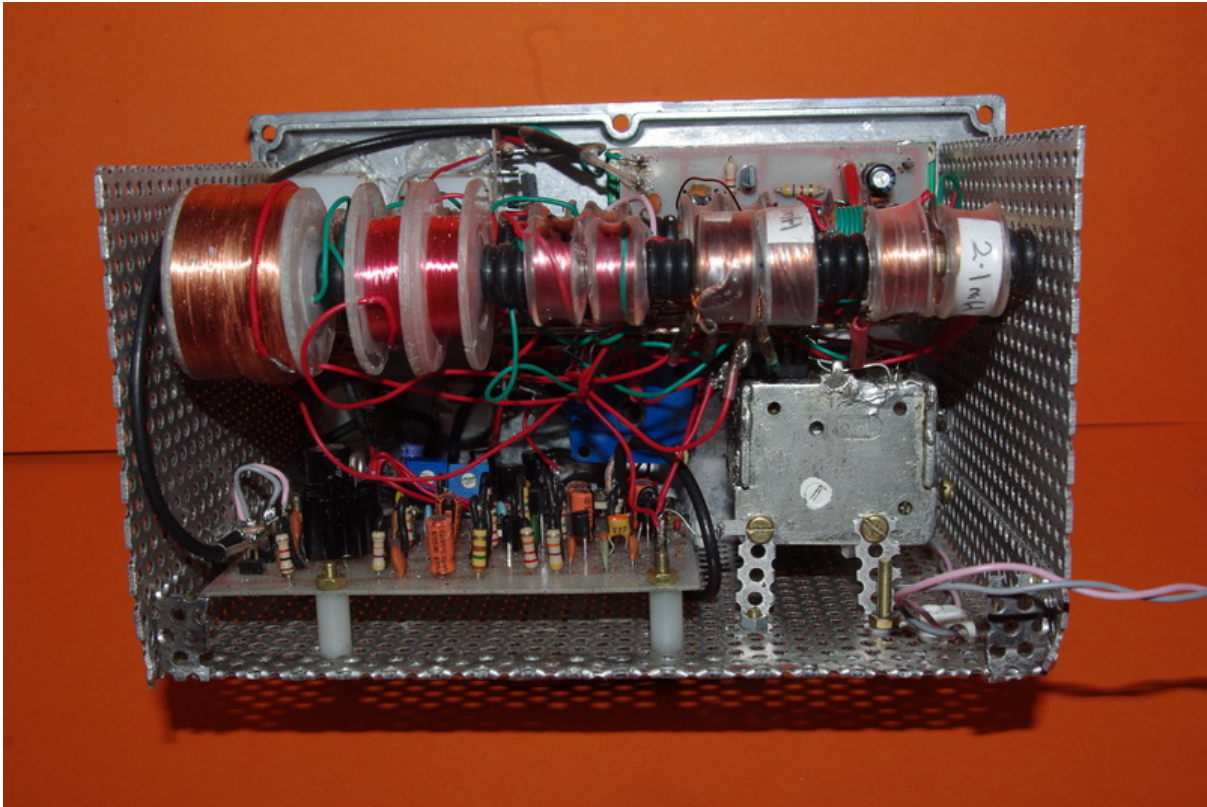

Overview 2

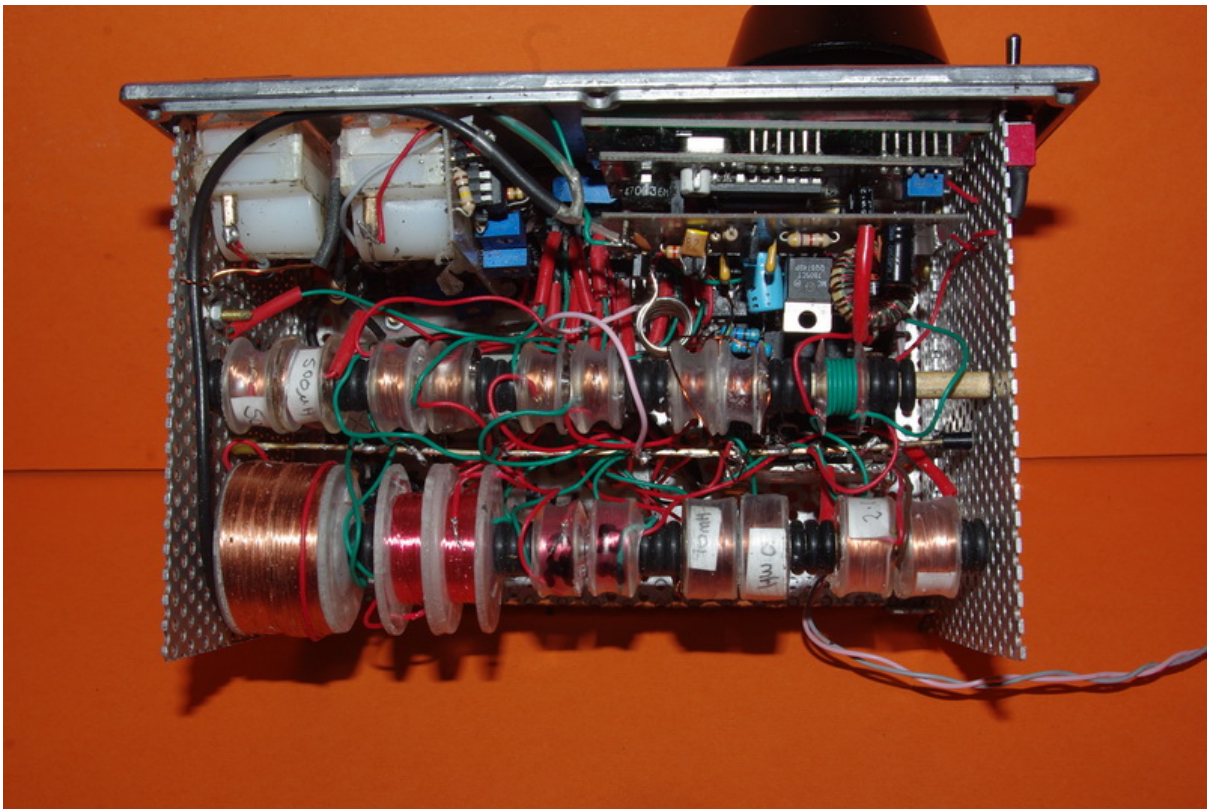

Over view 3

## 2. Level meters

These are based on my RF mV meter at:-

<http://makearadio.com/visitors/nick-rf-meter.php>

and are intended as indicators only, for absolute readings they will need to be calibrated. The RF one against frequency as well. They are identical with two exceptions C4 and C6 these are 100microF for the audio meter and 100nF for the RF meter.

The completed board measures 0.9inch by 2.5 inch

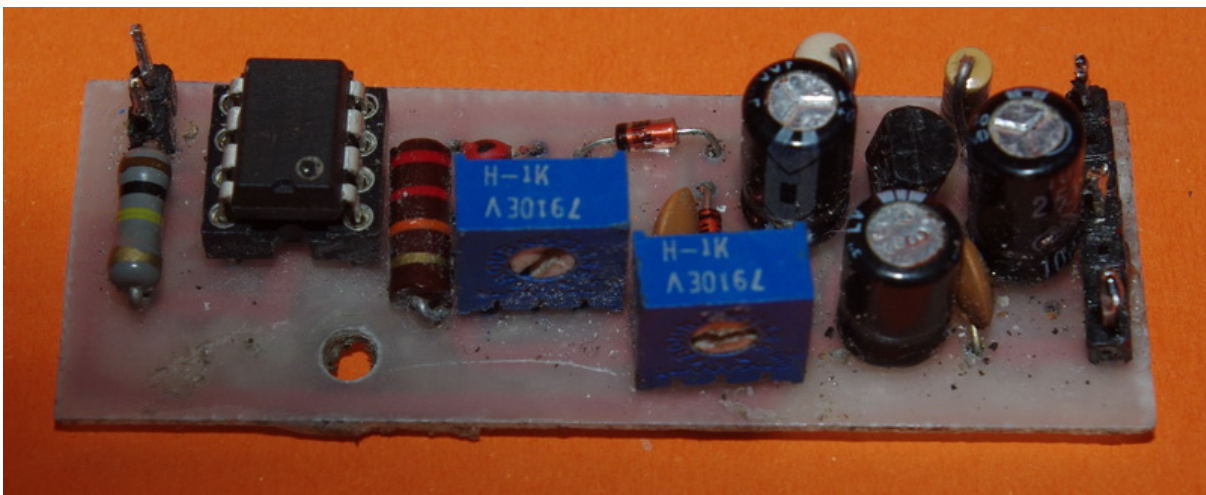

**completed AF board**

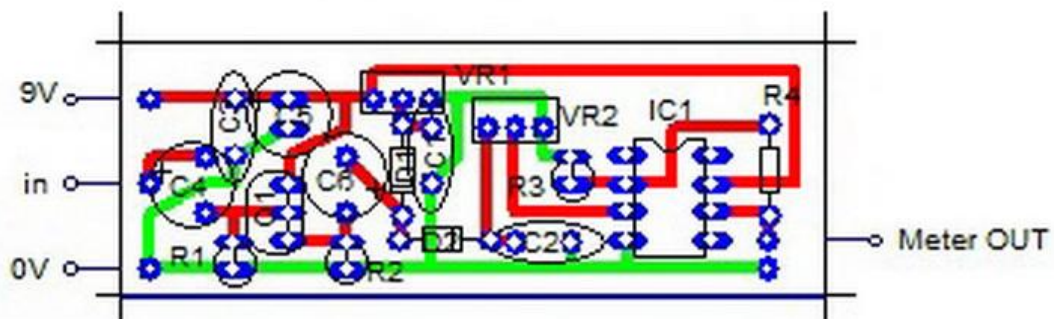

**component placement**

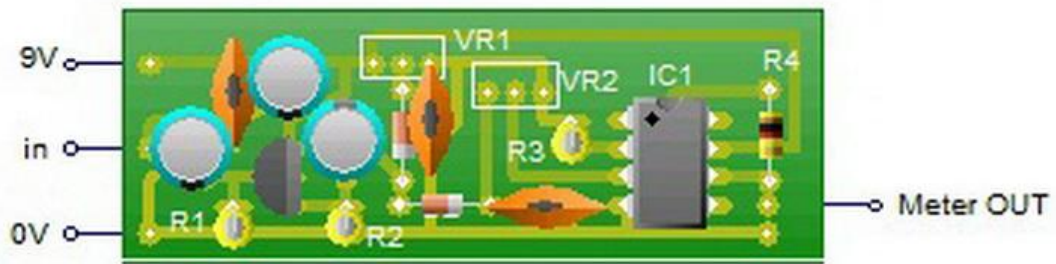

**Real world**

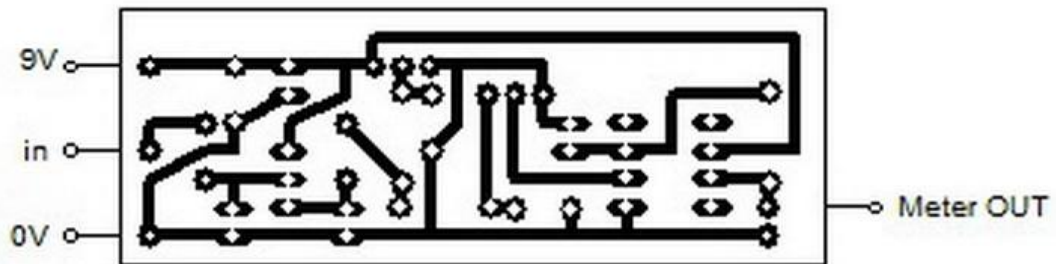

**Track layout**

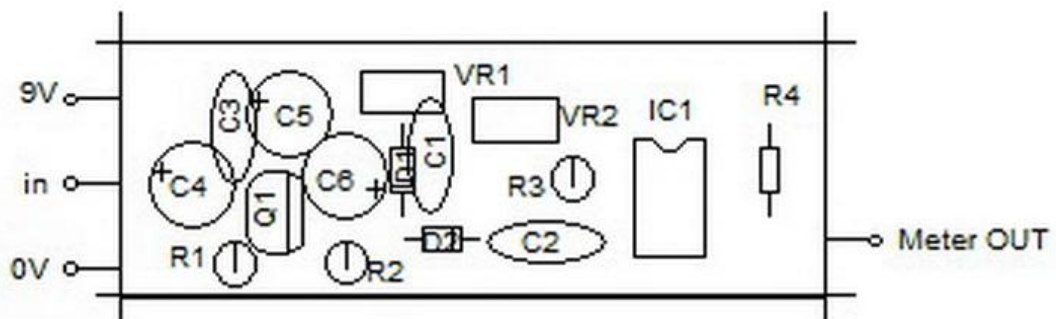

**Silk screen**

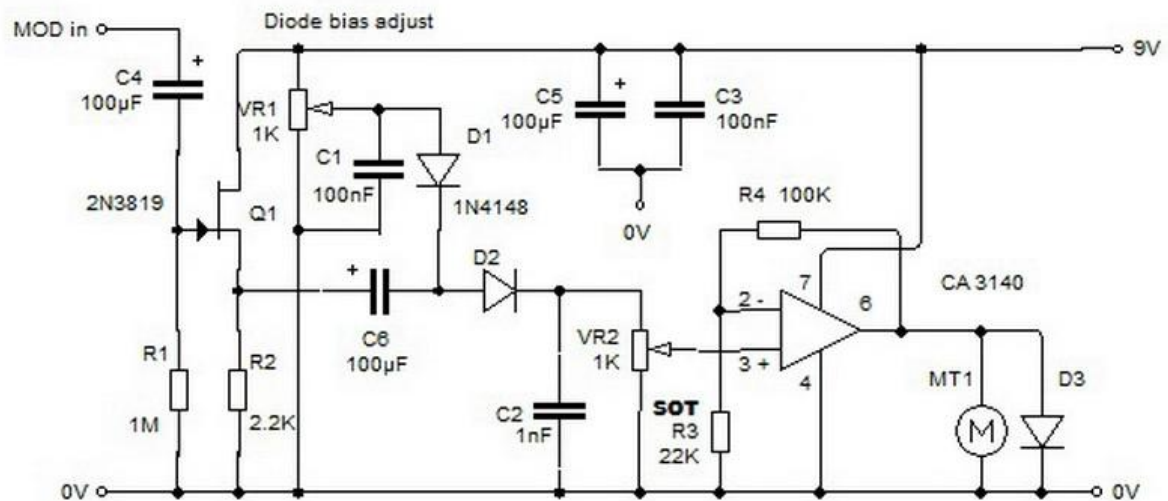

setup and calibration is covered at:

<http://makearadio.com/visitors/nick-rf-meter.php>

### **3. Frequency meter preamp**

This is based on a design I found on the net, unfortunately I can't find the URL again I was lucky first time round. It is designed to fit as a piggy back board on the frequency meter module I used that I obtained from E-Bay from "jpl995" and was listed as **"FREQUENCY COUNTER 1HZ-80MHZ WITH 1HZ RESOLUTION"**

**Please note the wire link is replaced by a capacitor see diagram, the dc coupling option doesn't apply. The only point to mention is the 5V regulator this is there to protect the frequency meter module input as it ensures no more than a 5V peak signal can be applied**

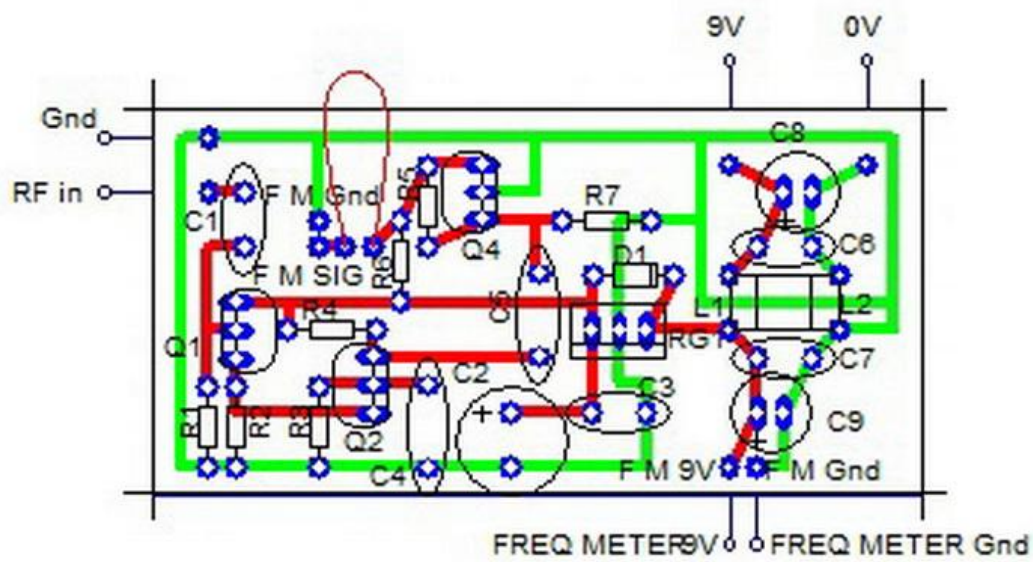

component placement

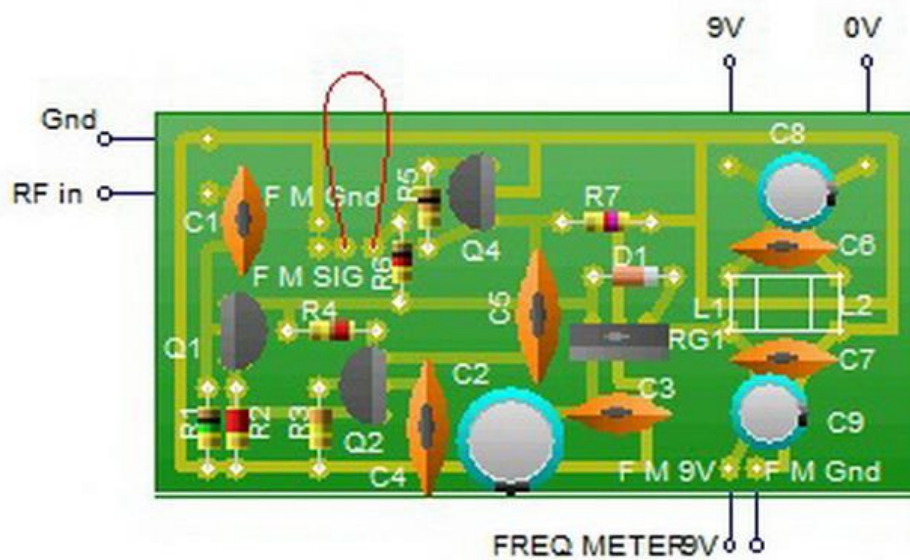

Real world

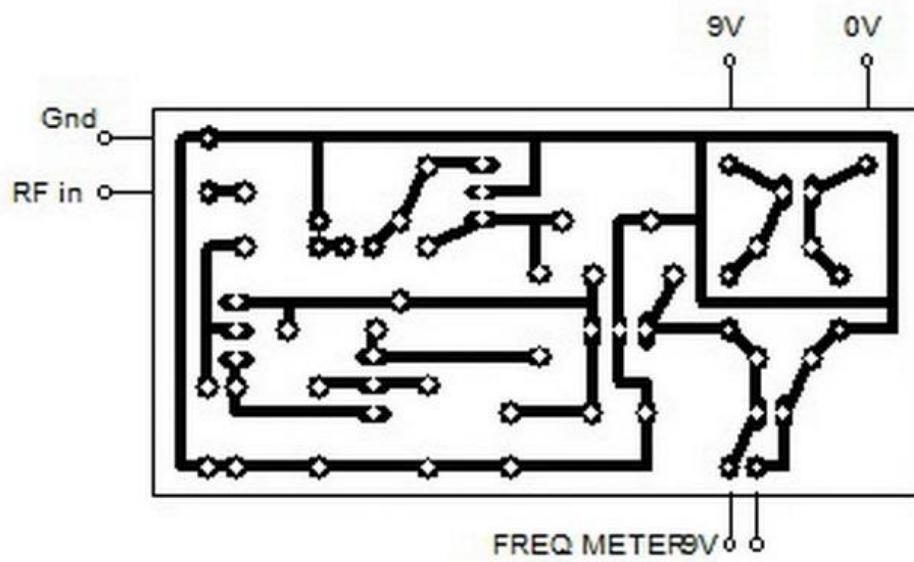

Track layout

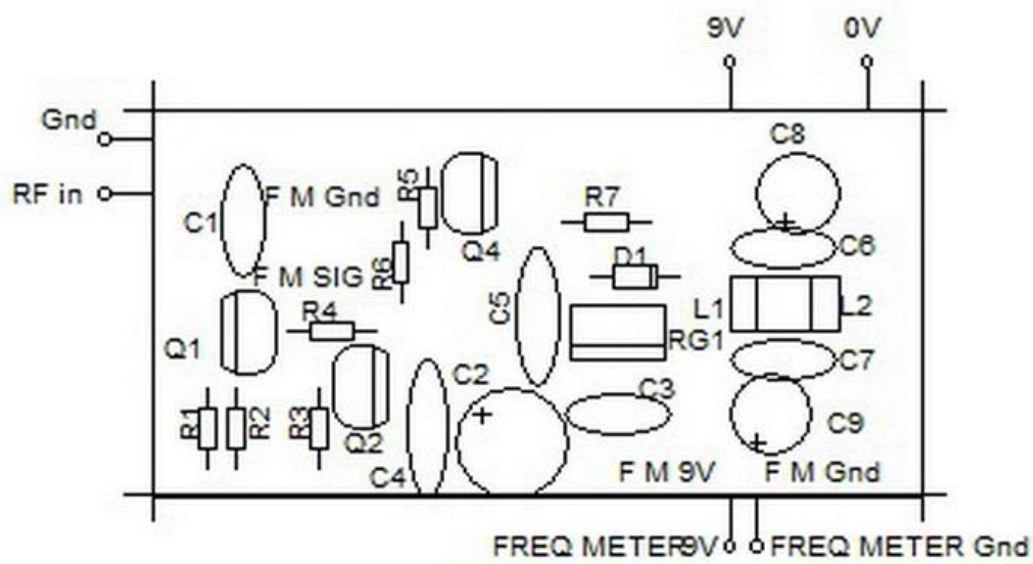

Silk screen

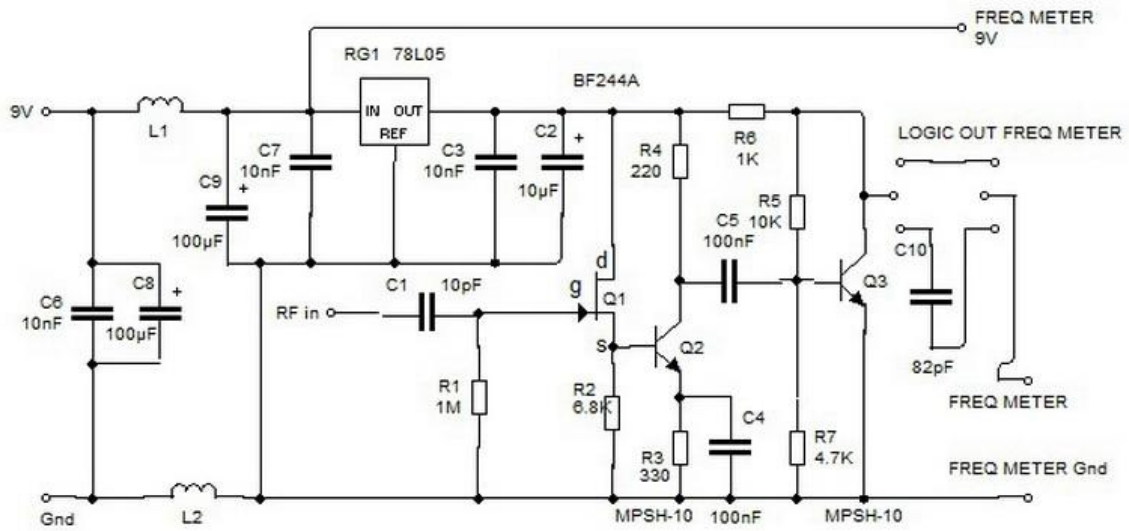

### Coil Table

Coil	f lo	RMS	f hi	RMS	Turns	SWG	$L_H$
1	17K	1.22	38K	0.50	3500	40SWG	200m
2	28K	1.00	68K	0.34	2000	0.18mm	65m
3	54K	1.25	96K	0.40	1500	0.18mm	18m
4	79K	1.52	180K	0.54	1000	0.18mm	10m
5	168K	1.49	370K	0.59	500	0.18mm	2.1m
6	360K	0.96	920K	1.00	250	28SWG	500
7	830K	0.40	2.5M	0.72	100	28SWG	100
8	2.2M	0.62	6.3M	0.80	45	0.45mm	38
9	5.3M	0.41	19.5M	0.80	16	0.45mm	62
10	9.5M	0.40	32M	0.30	7	1mm	2.4
11	25M	N/M	54M	N/M	4	1mm	n/m

- 1 Inductance values no cores used
- 2 Inductance turns for separate L1 & L2
- 3 Coil 6.5mm I.D by 5mm
- 4 395 pF tuning Capacitor
- 5 Inductance microH unless stated
- 6 Coil set 10 wound on same former
- 7 Coil set 11 air spaced no former

**NB these values are for my build yours will be different the table is intended as a rough guide only.**

Before anybody asks I opted for an analogue approach rather than DDS ( dirty digital synthesis ) as it is easier for the average person to build at home and does not involve the use of a pic etc.

I also apologise for the delay in publishing this design as I am still suffering with my poor health

Hope you find this a useful design 73 for now de Nick G0CWA

Any comments will be gratefully received and as usual I can be contacted by [e-mail](#) or via [The RadioBoard](#) and [QRZ](#) forums as G0CWA.

I cannot guarantee to see your questions if posted elsewhere

REMEMBER TO CHECK THE PCB TRACK LAYOUTS AND MIRROR THEM IF NEEDED. I HAVE PRESENTED THEM AS "X-RAY" VIEWS OF THE FINAL BOARD  
!!!!

***PLEASE NOTE if you downloaded this document from anywhere but :***

***<http://makearadio.com>***

***or***

***<http://makearadio.com/visitors/index-nick.php>***

***I cannot guarantee you will have the latest version, Please inform Dave if it was downloaded from another site. Dave's site is the ONLY ONE I HAVE AUTHORISED to distribute/and display my projects and documents. However links to the projects are permitted with Daves permission.***

**I do not supply kits, parts, PCB's or build boards for my projects but am more than willing to help talk you through a build or fault finding via my normal contact methods, or even SKYPE if required for direct contact.**